

Product Components

- ① 8500 Electric Strike Body
- ② Horizontal Lockdown Shims
- ③ #4-40 Screws
- ④ 12 & 24 Volt Pigtails

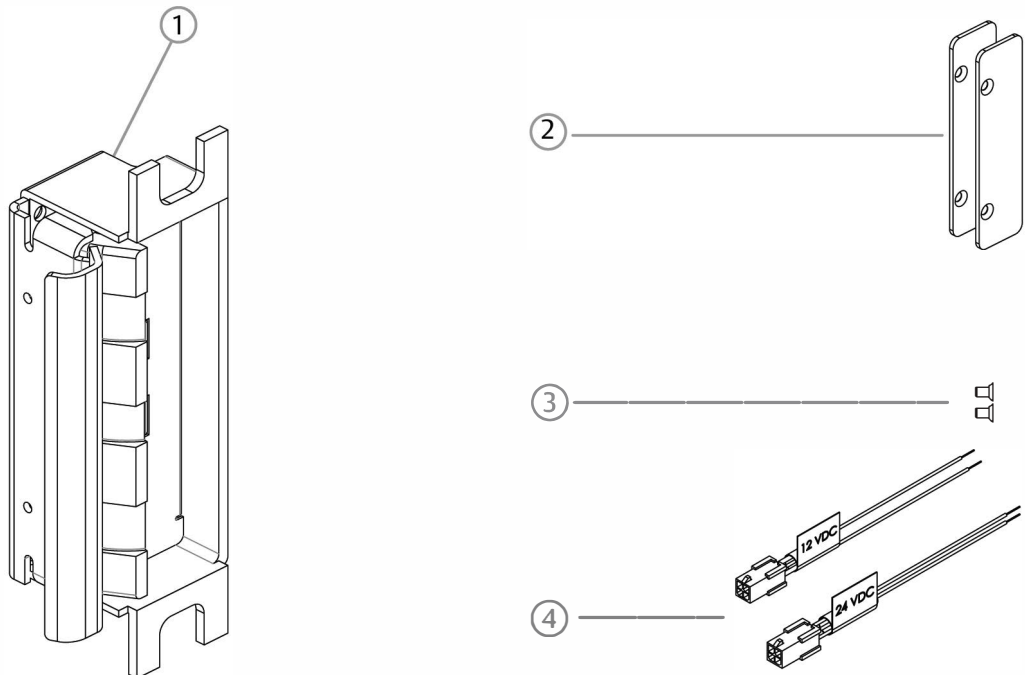

Electrical Specifications

ELECTRICAL RATINGS FOR SOLENOID	CONTINUOUS DUTY		INTERMITTENT DUTY*	
	12VDC	24VDC	12-16VAC	24VAC
Resistance in Ohms	50	200	50	200
Amps	.24	.12	.24-.32	.12

Solenoids are rated at +/- 10% indicated value.

*10% max duty cycle (2 min. max on time)

MINIMUM WIRE GAUGE REQUIREMENTS	SOLENOID VOLTAGE	
	12VDC	24VDC
200 feet or less	18 gauge	20 gauge
200 - 300 feet	16 gauge	18 gauge
300 - 400 feet	14 gauge	16 gauge

Installation Directions

CAUTION! Before connecting any device at the installation site, verify input voltage using a multimeter. Many power supplies and low voltage transformers operate at higher levels than listed. Any input voltage exceeding 10% of the solenoid rating may cause severe damage to the unit and will void the warranty.

Evaluate Opening

1. Verify opening is plumb and square and evaluate latch bolt condition. For important details, see “Troubleshooting Tips” on page 3.

Prepare Strike

2. The electric strike ships in fail secure mode. If you need to convert the unit to fail safe, see Diagram 3 on page 5. Please note that operation in fail safe mode removes the fire rating of the electric strike.

Prepare Frame

3. Remove dustbox and prepare door jamb per the template detail on page 6. Be sure to allow enough room behind the electric strike in the cut out to avoid pinching the wires.

Install Deadlatch Platform

4. Select correct option. Determine platform position appropriate for the lockset (see Diagram 4 on page 5).

5. Insert deadlatch platform into the keeper slot as shown in Diagram 5 on page 5, ensuring that the screw holes in the deadlatch platform foot and outer casing are aligned. It may be necessary to slightly retract the keeper in order to properly seat the deadlatch platform fastening foot.

6. Fasten the deadlatch platform to the electric strike using the #4-40 screw provided.

Install Strike in Frame

7. Select and electrically connect the appropriate 12 or 24 Volt pigtail to match system power as illustrated in Diagram 1 below.

For 12V AC/DC or 16V AC, the pigtail marked “12 VDC” should be used. For 24V AC/DC, the pigtail marked “24 VDC” should be used. If no connector is present, configure the wires as shown in Diagram 1.

8. If using Latchbolt Monitor (LBM) or Latchbolt Strike Monitor (LBSM), see Diagram 2 on page 2.

9. Connect the 12 or 24 Volt pigtail to the electric strike.

10. Insert electric strike in jamb cutout and install the appropriate faceplate using the #12-24 screws provided. Partially tighten screws and close the door.

11. Verify lockset’s deadlatch is positioned on top of the deadlatch platform, and does not touch the faceplate. See troubleshooting tips for more information.

Set Horizontal Adjustment

12. Open the door and pull the electric strike flush with the inside face of the frame (in the direction of the opening), and tighten screws.

13. Close the door. If excessive movement (door play) when latched, remove strike from the jamb cutout, and add one or two of the horizontal lockdown shims to the front face of the electric strike (See Diagram 6 on page 6). Ensure the horizontal lockdown shim is making contact with the inside face of the frame. Check again and add or remove additional shims until proper horizontal adjustment is achieved.

Note: The gap between the door and the frame at the strike plate varies. Verify latchbolt guarding with door closed.

DIAGRAM 1: 12V to 24V CONVERSION

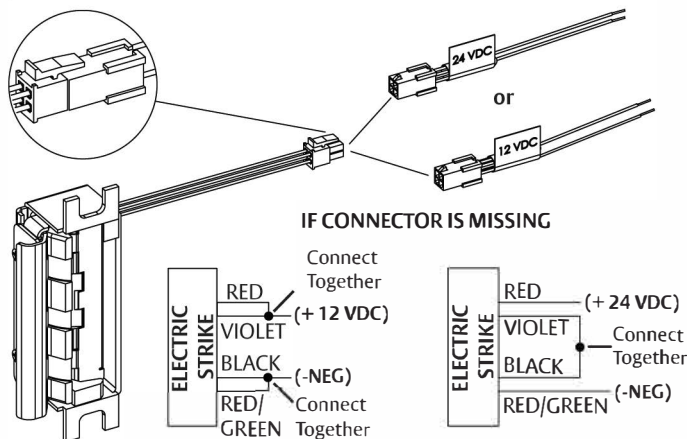

DIAGRAM 2: LBM & LBSM WIRING

LBM WIRING

White	Common
Orange	Normally Open
Green	Normally Closed

LBSM WIRING

Brown	Common
Blue	Normally Open
Yellow	Normally Closed



NOTE: In order to ensure proper catch and release of the latchbolt, the 8500 electric strike requires that the opening be plumb and square .

Door sag and latchbolt wear are two common conditions that may prevent an electric strike from working properly. Here are some quick tips to ensure the HES 8500 performs at its best:

EVALUATING LATCH BOLT CONDITION

Poorly constructed, worn or damaged latchbolts may not interact properly with the ramp of an electric strike. Check the condition of your latchbolt by lightly pressing the tip of the latchbolt at a 45 degree angle to the door face. (See Figure 1). The latchbolt should be pushed easily into the door.

If abnormal resistance is encountered, apply a lubricant to the inside of the latchbolt opening while pressing the latchbolt . (See Figure 2). If this does not correct the friction, additional maintenance on the latchbolt may be required. Note: Check with the latchbolt manufacturer regarding proper latchbolt maintenance and approved lubricants.

ACCOMMODATING DOOR SAG

Most doors experience some sagging over time. To check for door sag, look at the location of the lock's deadlatch in relation to the 8500's deadlatch platform. The deadlatch should rest on the deadlatch platform. If the deadlatch contacts the faceplate or the edge of the 8500's body, the latchbolt may not be fully released when the strike is activated causing the door not to be released.

To correct this condition, remove the 8500 and cut material from the bottom edge of the frame opening and possibly the mounting tabs (Note: make sure to sure to retain the mounting hole). This allows the 8500 to be shifted down slightly in the frame. Reinstall the 8500, using the SD faceplate instead of the standard faceplate.

If this does not correct the issue, additional maintenance on the door may be necessary.

STRIKE LUBRICATION

Lubrication of the 8500 electric strike is not necessary.

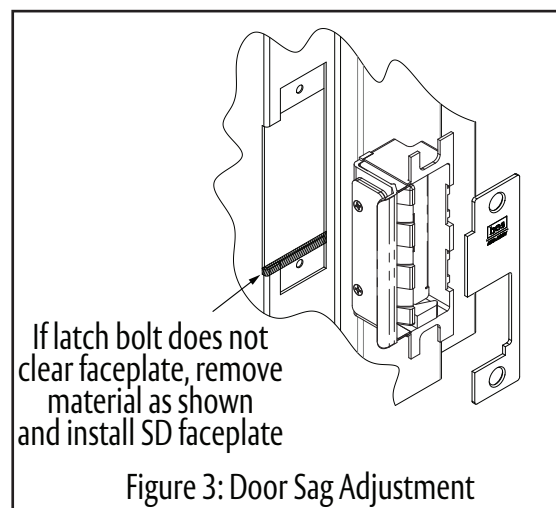
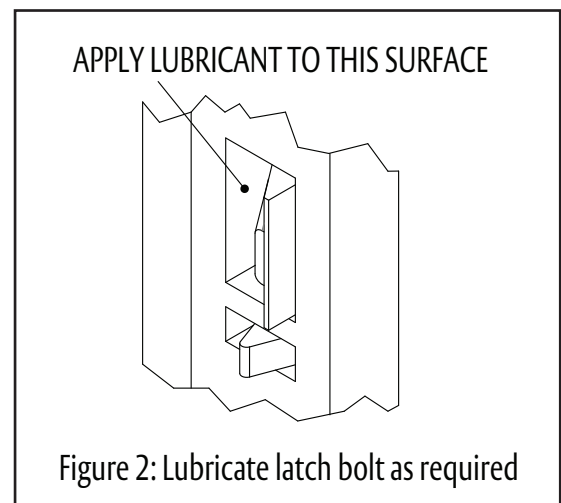
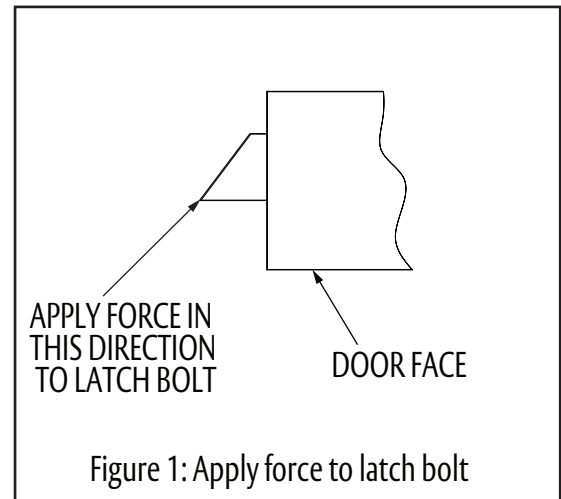

8500 Options

Cl = centerline of faceplate
2nd line = centerline of faceplate opening

851M

Compatible with mortise locksets:
Sargent (8100, 8200, 9200)

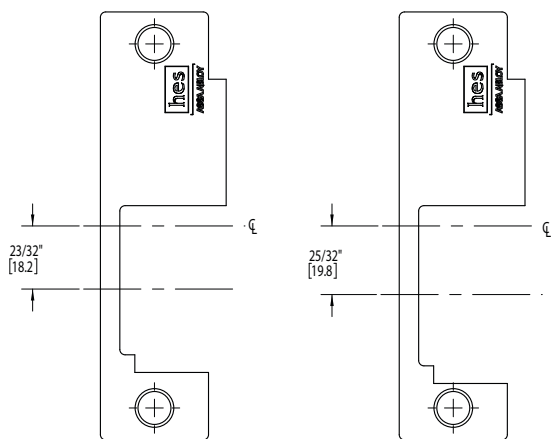
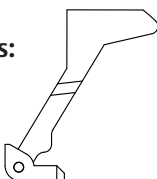

852K

Compatible with mortise lockset:
Corbin Russwin (ML 2000)

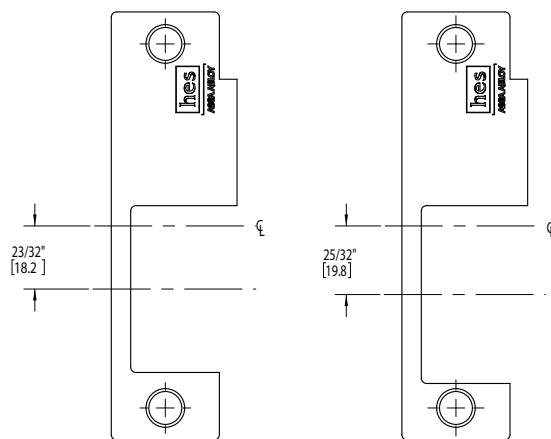

852L

Compatible with mortise lockset:
Schlage

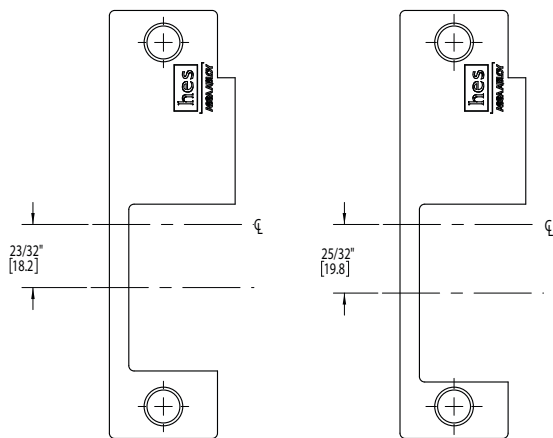
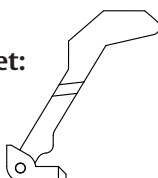

852M

Compatible with mortise locksets:
Yale (8700* & 8800), Accurate,
Falcon, Kaba Ilco/Unican

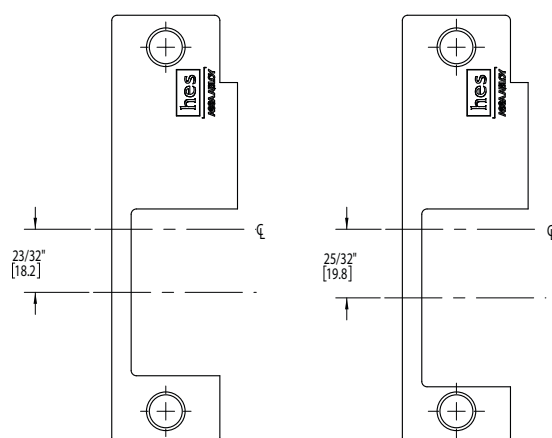
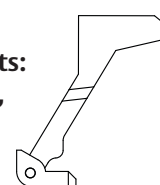

* Manufactured after 2005.
Contact HES Customer Support for more information.

DIAGRAM 3: Fail Safe Conversion

Fail Safe

LBSM Fail Safe*

LBSM

Fire Screw

- Remove and discard the fire screw (Located under the UL fire label).
- Loosen screws, but do not remove them.
- Move screws to the Fail Safe position as shown.
- Tighten screws.
- Discard the UL label that's located over the screw, as well as the UL label located inside the strike pocket.

***Note:** If you are using LBSM and you want to convert to Fail Safe mode, follow steps a, b, and c. Then move the switch to the Fail Safe position, as shown in Diagram 3.

DIAGRAM 4: Deadlatch Platform Position

Lockset	Platform Style	Platform Position 1	Lockset	Platform Style	Platform Position 2
Sargent 8100, 8200, 9200 Yale 8800 Accurate Falcon Kaba Ilco/Unican	M	<p>LH/RHR handed position shown</p>	Yale 8700 *	M	
Corbin Russwin ML 2000	K		Schlage L9000	L	

* Manufactured after 2005. Contact HES Customer Support for more information

DIAGRAM 5: Deadlatch Platform Installation

Position 1 (RH/LHR)

Position 2

Position 1 (LH/RHR)

Push keeper down for easier insertion.

Strike shown in LH/RHR position

TRADEMARK HARDWARE
WORLD OF QUALITY HARDWARE
WWW.TMHW.COM

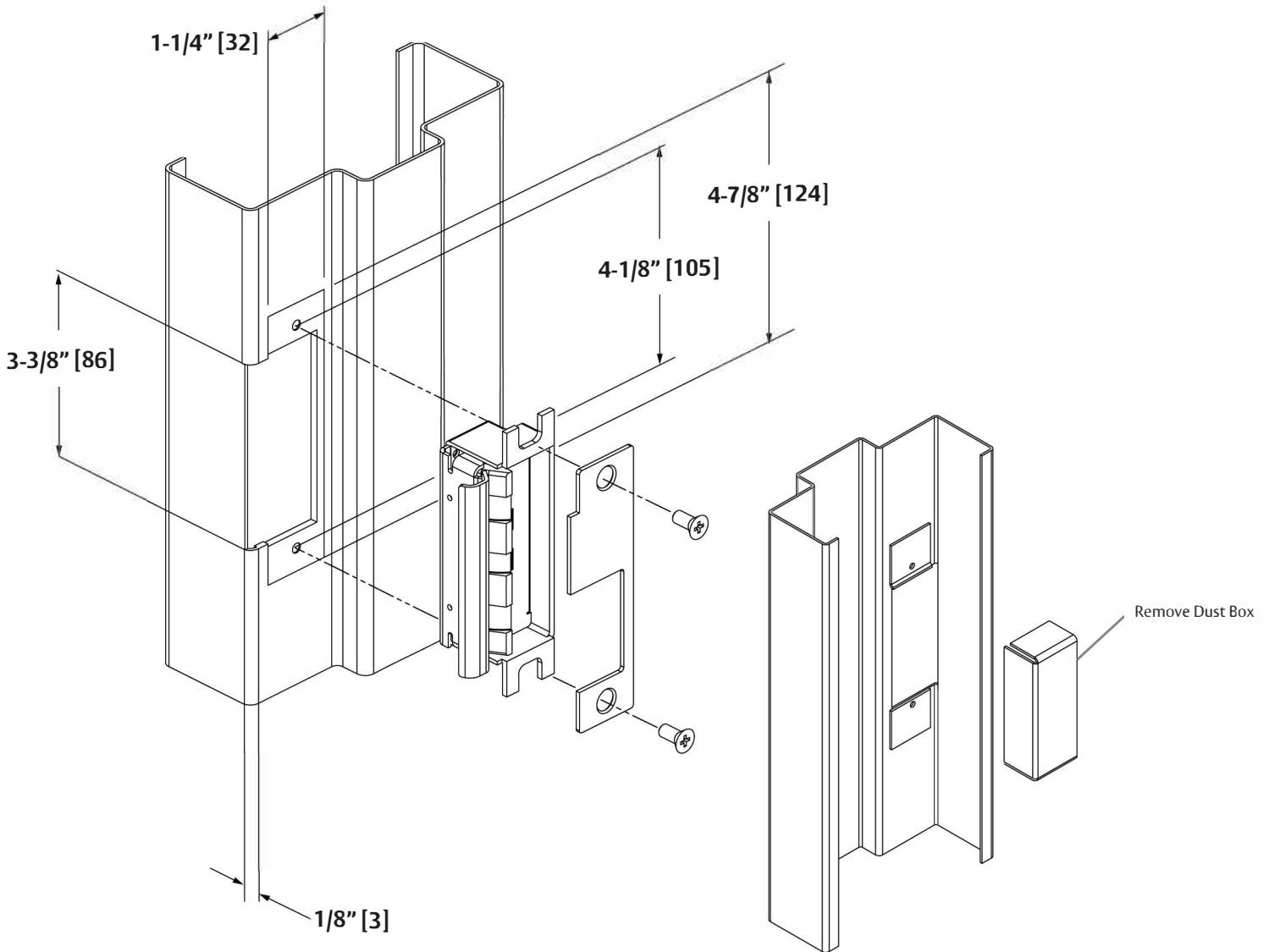

***Note:** The 8500 electric strike will require removal of dust boxes of less than 1-3/8" in depth. Remove additional material as needed to provide clearance for electric strike and wires.

DIAGRAM 6: Horizontal Lockdown Shim Installation

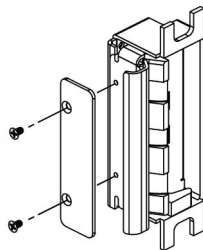

1 Shim = 1/16" [1.6]
 2 Shims = 1/8" [3.2]